**Underground installation of flexible
glass-reinforced pipes based
on unsaturated polyester resin
(GRP-UP) —**

Part 2:
Comparison of static calculation methods

*Installation enterrée de canalisations flexibles renforcées de fibres
de verre à base de résine polyester insaturée (GRP-UP) —*

Partie 2: Comparaison de méthodes de calcul statique



PDF disclaimer

This PDF file may contain embedded typefaces. In accordance with Adobe's licensing policy, this file may be printed or viewed but shall not be edited unless the typefaces which are embedded are licensed to and installed on the computer performing the editing. In downloading this file, parties accept therein the responsibility of not infringing Adobe's licensing policy. The ISO Central Secretariat accepts no liability in this area.

Adobe is a trademark of Adobe Systems Incorporated.

Details of the software products used to create this PDF file can be found in the General Info relative to the file; the PDF-creation parameters were optimized for printing. Every care has been taken to ensure that the file is suitable for use by ISO member bodies. In the unlikely event that a problem relating to it is found, please inform the Central Secretariat at the address given below.



COPYRIGHT PROTECTED DOCUMENT

© ISO 2007

All rights reserved. Unless otherwise specified, no part of this publication may be reproduced or utilized in any form or by any means, electronic or mechanical, including photocopying and microfilm, without permission in writing from either ISO at the address below or ISO's member body in the country of the requester.

ISO copyright office
Case postale 56 • CH-1211 Geneva 20
Tel. + 41 22 749 01 11
Fax + 41 22 749 09 47
E-mail copyright@iso.org
Web www.iso.org

Published in Switzerland

Contents

Page

Foreword.....	iv
Introduction	v
1 Scope	1
2 Normative references	1
3 Symbols and abbreviated terms	1
4 Soil-load distribution.....	10
5 Soil load	10
5.1 General.....	10
5.2 Initial loadings.....	10
5.3 Long-term loading	15
6 Traffic loads.....	15
6.1 General.....	15
6.2 AWWA procedure	16
6.3 ATV procedure	18
7 Deflections.....	20
7.1 Resulting from vertical load	20
7.2 Aspects not covered by AWWA or ATV	26
7.3 Irregularities in the installation	26
8 Circumferential bending strain.....	27
8.1 AWWA procedure	27
8.2 ATV procedure	27
9 Buckling.....	29
9.1 General.....	29
9.2 AWWA procedure	29
9.3 ATV procedure	31
10 Internal-pressure effects.....	34
10.1 General.....	34
10.2 Pressure strain.....	34
10.3 Combined loading.....	34
10.4 Calculations based on stress	35
Bibliography	36

Foreword

ISO (the International Organization for Standardization) is a worldwide federation of national standards bodies (ISO member bodies). The work of preparing International Standards is normally carried out through ISO technical committees. Each member body interested in a subject for which a technical committee has been established has the right to be represented on that committee. International organizations, governmental and non-governmental, in liaison with ISO, also take part in the work. ISO collaborates closely with the International Electrotechnical Commission (IEC) on all matters of electrotechnical standardization.

International Standards are drafted in accordance with the rules given in the ISO/IEC Directives, Part 2.

The main task of technical committees is to prepare International Standards. Draft International Standards adopted by the technical committees are circulated to the member bodies for voting. Publication as an International Standard requires approval by at least 75 % of the member bodies casting a vote.

In exceptional circumstances, when a technical committee has collected data of a different kind from that which is normally published as an International Standard ("state of the art", for example), it may decide by a simple majority vote of its participating members to publish a Technical Report. A Technical Report is entirely informative in nature and does not have to be reviewed until the data it provides are considered to be no longer valid or useful.

Attention is drawn to the possibility that some of the elements of this document may be the subject of patent rights. ISO shall not be held responsible for identifying any or all such patent rights.

ISO/TR 10465-2 was prepared by Technical Committee ISO/TC 138, *Plastics pipes, fittings and valves for the transport of fluids*, Subcommittee SC 6, *Reinforced plastics pipes and fittings for all applications*.

This second edition cancels and replaces the first edition (ISO/TR 10465-2:1999), which has been technically revised to take into account changes made to methods in base documents ATV-A 127 and AWWA M-45 (see Introduction).

ISO 10465 consists of the following parts, under the general title *Underground installation of flexible glass-reinforced pipes based on unsaturated polyester resin (GRP-UP)*:

- *Part 1: Installation procedures* [Technical Specification]
- *Part 2: Comparison of static calculation methods* [Technical Report]
- *Part 3: Installation parameters and application limits* [Technical Report]

Introduction

Work in ISO/TC 5/SC 6 (now ISO/TC 138) on writing International Standards for the use of glass-reinforced plastics (GRP) pipes and fittings was approved at the subcommittee meeting in Oslo in 1979. An ad hoc group was established and the responsibility for drafting various International Standards was later given to a Task Group (now ISO/TC 138/SC 6).

At the SC 6 meeting in London in 1980, Sweden proposed that a working group be formed to develop documents regarding a code of practice for GRP pipes. This was approved by SC 6, and Working Group 4 (WG 4) was formed for this purpose. Since 1982, many WG 4 meetings have been held which have considered the following matters:

- procedures for the underground installation of GRP pipes;
- pipe/soil interaction with pipes having different stiffness values;
- minimum design parameters;
- overview of various static calculation methods.

During the work of WG 4, it became evident that unanimous agreement could not be reached within the working group on the specific methods to be employed to address these issues. It was therefore agreed that all parts of the code of practice should be made into a type 3 Technical Report, and this was the form in which this part of ISO 10465 was first published in 1999. Since then the ISO rules dealing with the classification of document types have been revised and this has resulted in the three parts of ISO 10465 now being published as either a Technical Specification or a Technical Report.

ISO 10465-1, published as Technical Report in 1993 and revised as a Technical Specification in 2007, describes procedures for the underground installation of GRP pipes. It concerns particular stiffness classes for which performance requirements have been specified in at least one product standard, but it can also be used as a guide for the installation of pipes of other stiffness classes.

This part of ISO 10465, published as a Technical Report in 1999 and revised in 2007, presents a comparison of the two primary methods used internationally for static calculations on underground GRP pipe installations.

These methods are

- a) the ATV method given in ATV-A 127, *Guidelines for static calculations on drainage conduits and pipelines*, and
- b) the AWWA method given in AWWA manual M-45, *Fiberglass pipe design*.

ISO 10465-3, published as a Technical Report in 2007, gives additional information, which is useful for static calculations primarily when using an ATV-A 127 type design system in accordance with this part of ISO 10465, on items such as:

- parameters for deflection calculations;
- soil parameters, strain coefficients and shape factors for flexural-strain calculations;
- soil moduli and pipe stiffness for buckling calculations with regard to elastic behaviour;
- parameters for rerounding and combined-loading calculations;

the influence of traffic loads;

the influence of sheeting;

safety factors.

This Technical Report is not to be regarded as an International Standard. It is proposed for provisional application so that experience may be gained on its use in practice. Comments should be sent to the secretariat of TC 138/SC 6.

Underground installation of flexible glass-reinforced pipes based on unsaturated polyester resin (GRP-UP) —

Part 2: Comparison of static calculation methods

1 Scope

This part of ISO 10465 presents a comparison of the ATV and AWWA methods for static calculations on underground GRP pipe installations. It is intended that this comparison will encourage the use of both procedures for GRP pipes conforming to International Standards.

It is not the intent of this part of ISO 10465 to cover all the details of the two methods. Some aspects are, of necessity, very complex, and for a full understanding the original documents need to be studied in detail. Rather, the intention is to give a general overview and comparison of the key elements so that the user can more easily understand and appreciate the differences between the two procedures and their similarities.

2 Normative references

The following referenced documents are indispensable for the application of this document. For dated references, only the edition cited applies. For undated references, the latest edition of the referenced document (including any amendments) applies.

ATV-A 127, *Guidelines for static calculations on drainage conduits and pipelines*, 3rd edition, August 2000 (German Association for Water Pollution Control)

AWWA M-45, *Fiberglass pipe design manual M-45*, 2005 (American Water Works Association)

3 Symbols and abbreviated terms

For the purposes of this document, the following symbols apply.

NOTE 1 This clause also contains symbols and abbreviations from ISO 10465-1 and ISO 10465-3 for completeness.

NOTE 2 Several identical symbols are used in ATV-A 127 and AWWA M-45 to represent different quantities, and where this occurs, the origin of the symbol is given in the rightmost column.

NOTE 3 The format of the symbols listed here has been aligned as far as practicable with the *ISO/IEC Directives*, part 2, namely they appear in Times New Roman italic font. This format may differ slightly from the format used in ATV-A 127 and AWWA M-45.

Symbol	Unit	Meaning
<i>AQL</i>	—	acceptable quality level
<i>a'</i>	—	effective relative projection
<i>a_f</i>	—	ageing factor (ATV)

a_f	—	distribution factor (AWWA)
B1, B2, B3, B4	—	embedment conditions
b	m	trench width at spring-line
b'	m	distance from trench wall to pipe (see Figure 1)
C_n	—	buckling scalar calibration factor
c_1, c_2, c_3, c_4	—	coefficients used to determine ζ
c_4	—	reduction factor
c_f	—	creep factor
$c_{h,qv}, c_{v,qh}, c_{v,qh*}, c_{h,qh}, c_{h,qh*}, c_{v,qv},$ $c_{v*}, c_{v,qh*}, c_{h,qh*}, c_{v*}$	—	deformation coefficients
D	mm	mean pipe diameter
D_f	—	shape factor
D_g	—	shape adjustment factor
D_L	—	deflection lag factor
D_{pr}	%	compaction (based on simple proctor)
d_e	m	external pipe diameter
d_i	m	internal pipe diameter
d_m	m	mean pipe diameter $[(d_e \times 1000) - e]$
d_v	mm	vertical deflection
d_{vA}	mm	maximum permissible long-term deflection
d_{vR}	mm	vertical deflection at rupture
$(d_v/d_m)_{\text{permissible}}$	%	maximum permissible relative vertical deflection
$(d_v/d_m)_{\text{initial}}$	%	initial vertical deflection
$(d_v/d_m)_{50}$	%	long-term (50 year) vertical deflection
$(d_v/d_m)_{\text{ult}}$	%	ultimate long-term vertical deflection
$E, E_o, E_p, E_{t,wet}$	N/m ²	apparent flexural moduli of pipe wall
$E', E_1, E_2, E_3, E_4, E'_s, E_s, E_{s,\sigma}, E_{20}$	N/m ²	soil deformation moduli
E_{TH}	N/m ²	tensile hoop modulus
e	mm	pipe wall thickness
e	—	base of natural logarithms (2,718 281 8)
F	—	compaction factor

F_A, F_E	kN	wheel loads
FS	—	calculated safety factor (ATV)
FS	—	design factor = 2,5 (AWWA)
FS_b	—	bending safety factor
FS_{pr}	—	pressure safety factor
f_1	—	reduction factor for creep
f_2	—	reduction factor for ground water in pipe zone
G1, G2, G3, G4	—	soil groups
HDB	—	extrapolated pressure strain at 50 years
H_{EVD}	m	environmental depth of cover
h	m	depth of cover to top of pipe
h_{int}	m	depth at which load from wheels interact
h_w	m	height of water surface above top of pipe
I	m ⁴ /m	second moment of area in longitudinal direction per unit length (of a pipe)
I_f	—	impact factor (AWWA)
i_f	N/mm ²	installation factor
K^*	—	coefficient for bedding reaction pressure
K'	—	modulus of deformation
K_1, K_2	—	ratio of horizontal to vertical soil pressure in soil zones 1 and 2
K_3	—	ratio of horizontal to vertical soil pressures in pipe-zone backfill, when backfill is at top of pipe (see ISO 10465-3:2007, Annex A)
k_{v2}	—	reduction factor to take into account the elastic-plastic soil mass law and preliminary deflections
k_x	—	bedding coefficient
L_1	m	load width parallel to direction of travel
L_2	m	load width perpendicular to direction of travel
$LLDF$	—	live load as a function of depth factor
M	—	sum of bending moments
M_p	—	multiple presence factor
M_s	N/m ²	composite constrained-soil modulus

M_{s1}	N/m ²	value of composite constrained-soil modulus from ISO 10465-3:2007, Table A.3
M_{s100}	N/m ²	composite constrained-soil modulus at 100 % SPD
M_{sb}	N/m ²	backfill soil constrained modulus
M_{sn}	N/mm ²	native soil constrained modulus
m_{qv}, m_{qh}, m_{qh}^*	—	moment factors
N	—	sum of normal forces
n_{10}	—	number of blows
P	N	magnitude of wheel load
PN	—	nominal pressure (pipe characteristic)
P	bar	internal pressure
P_f	—	probability of failure
P_v	MPa (N/mm ²)	internal under-pressure
P_w	N/m ²	working pressure
$P(X)$	—	probability function
P_{50}	bar	long-term (50 year) failure pressure
p	N/m ²	soil stress resulting from traffic loads
p_E	N/mm ²	pressure due to prismatic soil load
p_e	N/mm ²	external water pressure
p_F	N/m ²	soil stress due to traffic load according to Boussinesq
p_o	N/m ²	soil pressure due to uniformly distributed surface load
p_v	N/mm ²	soil pressure resulting from traffic load
q_a	MPa (N/mm ²)	permissible buckling pressure
q_c	MPa (N/mm ²)	critical buckling pressure
q_{cl}	MPa (N/mm ²)	critical buckling pressure under sustained load
q_{c^*w}	N/mm ²	horizontal bedding reaction for pipe and contents
q_h, q_v	N/mm ²	horizontal or vertical soil pressure on pipe
q_{h^*}	N/mm ²	horizontal bedding reaction pressure
q_{hLT}	N/mm ²	reduced long-term horizontal soil pressure
$q_{h,50}$	N/mm ²	long-term (50 year) horizontal soil pressure
q_{vLT}	N/mm ²	reduced long-term vertical soil pressure

$q_{v,50}$	N/mm ²	long-term (50 year) vertical soil pressure
q_{vwa}	N/mm ²	vertical load due to pipe and contents
R_h	—	depth-of-fill correction factor
R_w	—	water buoyancy reduction factor
r	—	rerounding factor (AWWA)
r	m	mean pipe radius (AWWA)
r_A, r_E	m	wheel radii (ATV)
r_c	—	rerounding coefficient
r_i	m	pipe internal radius
r_m	m	mean pipe radius
S_{Bh}	N/mm ²	horizontal bedding stiffness
S_{Bv}	N/mm ²	vertical bedding stiffness
S_b	—	long-term ring-bending strain capability of the pipe
S_c	—	soil support combining factor
S_k	N/mm ²	characteristic stress
S_O	N/m ²	long-term pipe stiffness
$S_{O,50}$	N/m ²	long-term pipe stiffness
\bar{S}_o	N/m ²	weighted long-term pipe stiffness
S_{OK}	N/m ²	long-term (50 year) pipe stiffness
S_{OL}	N/m ²	long-term (2 year) pipe stiffness
SPD	%	standard proctor density
S_p	N/m ²	initial pipe stiffness
$S_{p,50}$	N/m ²	long-term pipe stiffness
S_R	N/mm ²	$S_p \times 8 \times 10^{-6}$
$S_{R,50}$	N/mm ²	$S_{p,50} \times 8 \times 10^{-6}$
S_{Res}	N/mm ²	standard deviation of strength of pipe
$S_{Res,B}$	N/mm ²	standard deviation of strength of pipe below ground
S_S	N/mm ²	standard deviation of stress in pipe
$S_{S, B}$	N/mm ²	standard deviation of stress in pipe below ground
t_l	m	length of tyre footprint
t_w	m	width of tyre footprint

V_{RB}	—	system stiffness
V_S	—	stiffness ratio
W_C	N/m ²	vertical soil load on pipe
W_L	N/m ²	traffic load
X	—	safety index
y	%	coefficient of variation for initial tensile strength
y_R	%	coefficient of variation for tensile strength
z	%	coefficient of variation for initial ultimate deflection
α	°	half the bedding angle (see Figure 2)
α_B	—	reduction factor depending upon trench proportions and embedding conditions
α_{Bi}	—	value from ISO 10465-2:2007, Figure 5
α_D	—	snap-through coefficient
$\alpha_K, \alpha_{K_i}, \alpha_{K_e}$	—	correction factor for extreme curvature of inner or outer edge
β	°	half the horizontal support angle (see Figure 2)
β	°	(ATV) trench wall slope angle (see Figure 1)
γ_b	N/m ³	bulk density of backfill material
γ_w	N/m ³	density of pipe contents
δ	°	trench wall friction angle
δ_h	%	relative horizontal deflection
δ_v	%	relative vertical deflection
δ_{va}	%	negative relative vertical deflection due to traffic and vacuum load
δ_{vc}, δ_{vs}	%	negative relative vertical deflection due to soil load
δ_{v50}	%	long-term relative vertical deflection
δ_{vio}	%	positive relative vertical deflection due to backfilling in pipe zone
δ_{viv}	%	negative relative vertical deflection due to installation irregularities
δ_{vs50}	%	long-term negative relative vertical deflection due to soil load
δ_{vw}	%	negative relative vertical deflection due to weight of pipe

δ_w	%	relative vertical deflection due to traffic load
ε_b	—	bending strain caused by maximum permitted deflection
$\varepsilon_{\text{comp}}$	—	compressive strain due to vertical load
$\varepsilon, \varepsilon_t, \varepsilon_f$	—	calculated flexural strains in pipe wall
ε_{if}	—	flexural strain due to installation irregularities
$\varepsilon_{\text{max}}, \varepsilon_R$	—	maximum permissible strain due to pressure
ε_{PK}	—	initial bending tensile strain
ε_{PL}	—	long-term bending tensile strain
ε_{pr}	—	calculated strain in pipe wall due to internal pressure
$\bar{\varepsilon}_R$	—	weighted calculated value of outer fibre strain
ε_{tot}	—	total flexural strain
ε_v	—	flexural strain due to total vertical load
ε_{vio}	—	flexural strain due to backfilling in pipe zone
ε_{vw}	—	flexural strain due to weight of pipe
ε_w	—	flexural strain due to pipe contents
ε_{50}	—	long-term maximum bending strain caused by maximum permitted deflection
ζ	—	correction factor for horizontal bedding
$\eta, \eta_t, \eta_f, \eta_{\text{ff}}$	—	safety factors
η_{haf}	—	combined flexural safety factor
η_{hat}	—	combined tensile safety factor
$\eta_{\text{t,PN}}$	—	redefined safety factor for pipe to operate at PN
φ	°	soil internal friction angle
φ'	—	impact factor (ATV)
φ_s	—	variability factor for compacted soil
χ	—	coefficient of safety
χ_P	MN/m ³	unit weight (density) of pipe material
χ_s	N/m ³	unit weight (density) of soil
χ_w	N/m ³	unit weight (density) of water
κ, κ_β	—	reduction factor for distributed load according to silo theory when trench angle, β , is 90°

$\kappa_0, \kappa_{0\beta}$	—	reduction factor for distributed load according to silo theory when trench angle, β , is not 90°
$\lambda_B, \lambda_{B50}, \lambda_P, \lambda_{PG}, \lambda_{PG50}, \lambda_S$	—	concentration factors in soil next to pipe
λ_{\max}	—	maximum concentration factor
λ_{PLT}	—	long-term value for λ_P
λ_R	—	reduction factor for soil friction with time
μ_{Res}	N/mm ²	mean value of pipe strength (resistance)
$\mu_{Res, A}$	N/mm ²	mean value of strength (resistance) of pipe above ground
$\mu_{Res, B}$	N/mm ²	mean value of strength (resistance) of pipe below ground
$\mu_{S, B}$	N/mm ²	mean value of stress in pipe below ground
ν_s	—	Poisson ratio of soil
ρ	MN/m ³	density of pipe wall material
σ_c	N/mm ²	calculated compressive stress in pipe wall
σ_{PK}	—	initial bending tensile stress
σ_{PL}	—	long-term bending tensile stress
$\bar{\sigma}_R$	—	weighted bending tensile stress
σ_t	N/mm ²	calculated tensile stress in pipe wall

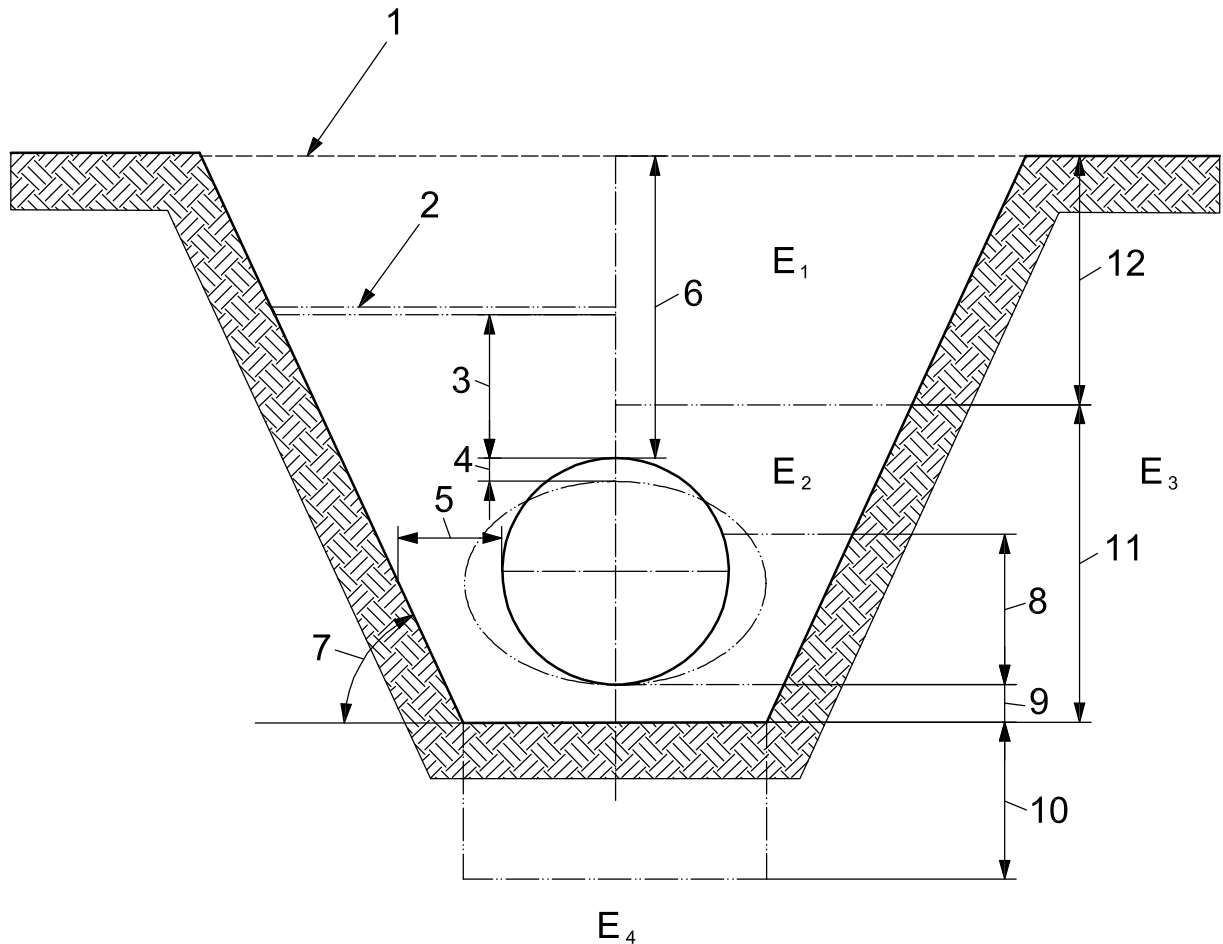
**Key**

- | | |
|--|--|
| 1 ground level | 7 trench wall angle, β |
| 2 water table | 8 thickness of primary embedment |
| 3 height of water surface above top of pipe, h_w | 9 thickness of bedding |
| 4 vertical deflection, d_v | 10 thickness of foundation (if required) |
| 5 distance from trench wall to pipe, b' | 11 pipe embedment |
| 6 depth of cover to top of pipe, h | 12 thickness of backfill |

Soil moduli zones

- E1 trench backfill above pipe embedment
 E2 pipe embedment
 E3 undisturbed native soil or *in situ* material to side of trench
 E4 undisturbed native soil or *in situ* material below bottom of trench (foundation material)

NOTE 1 The AWWA M-45 design manual uses M_{sb} in zone E₂.

NOTE 2 The AWWA M-45 design manual uses M_{sn} in zones E₃ and E₄.

Figure 1 — Symbols and terminology

4 Soil-load distribution

The assumed soil-load distributions used in ATV-A 127 and AWWA M-45, which are based on those made by M.G. Spangler, are shown in Figure 2. The main difference between the two assumptions is that ATV-A 127 considers the active horizontal pressure, whereas AWWA M-45, like Spangler, assumes the value to be zero. In ATV, the influence of active horizontal pressure is accounted for by using a value for K_2 which is in the range 0,1 to 0,4, when the system stiffness V_{RB} is less than 1 and depending on the type of soil in the pipe zone (zone E_3 in Figure 1).

ATV-A 127 uses horizontal (if required) and vertical deflections but AWWA M-45 only uses vertical deflection.

When, in the ATV system, the appropriate coefficients are used to calculate horizontal deflection using Spangler's assumption for soil-load distribution, the same deflection is obtained as with Spangler's system provided Spangler's E' is multiplied by 0,6.

Related to the question of soil distribution is the influence of the modulus of passive soil resistance. ATV introduces the horizontal soil stiffness term, S_{Bh} , equal to $0,6 \times \zeta \times E_2$ where ζ is the Leonhardt factor which accounts for the influence of the *in situ* (native) soil (zone E_3) and trench width (see Figure 1) and E_2 corresponds to Spangler's E' .

5 Soil load

5.1 General

The calculation of soil loads needs to consider both initial and long-term loadings. Short-term loading can be related to the initial pipe deflection, which is a property that is often used as a measure of installation quality. Long-term loading defines the expected long-term deflection of the pipe and is therefore related to service life.

5.2 Initial loadings

5.2.1 AWWA procedure

In the AWWA procedure, the soil loading is assumed to be a soil prism in all cases. The prism has a height equal to the depth of cover and its width is equal to the outside diameter of the pipe. The prismatic equation is always used, and arching or silo theory is not considered.

The vertical soil load, W_c , is calculated using Equation (1):

$$W_c = \gamma_b \times h \quad (1)$$

where

W_c is the vertical soil load, in N/m²;

γ_b is the bulk density of the soil (i.e. its weight per unit volume), in N/m³;

h is the depth of cover, in m.

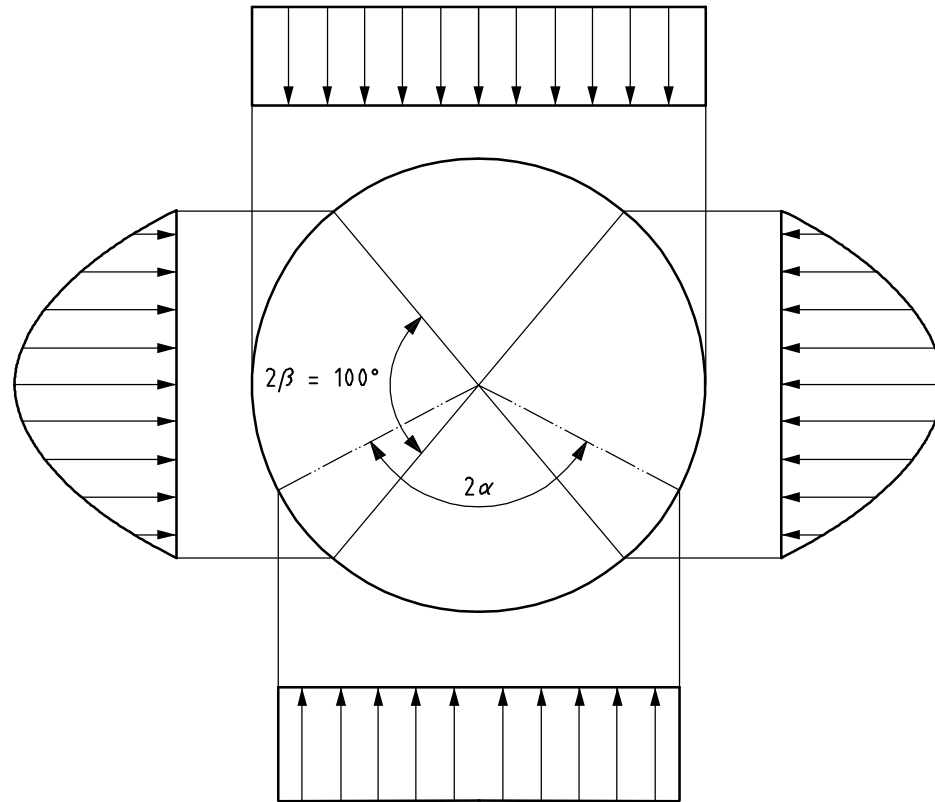

a) Spangler

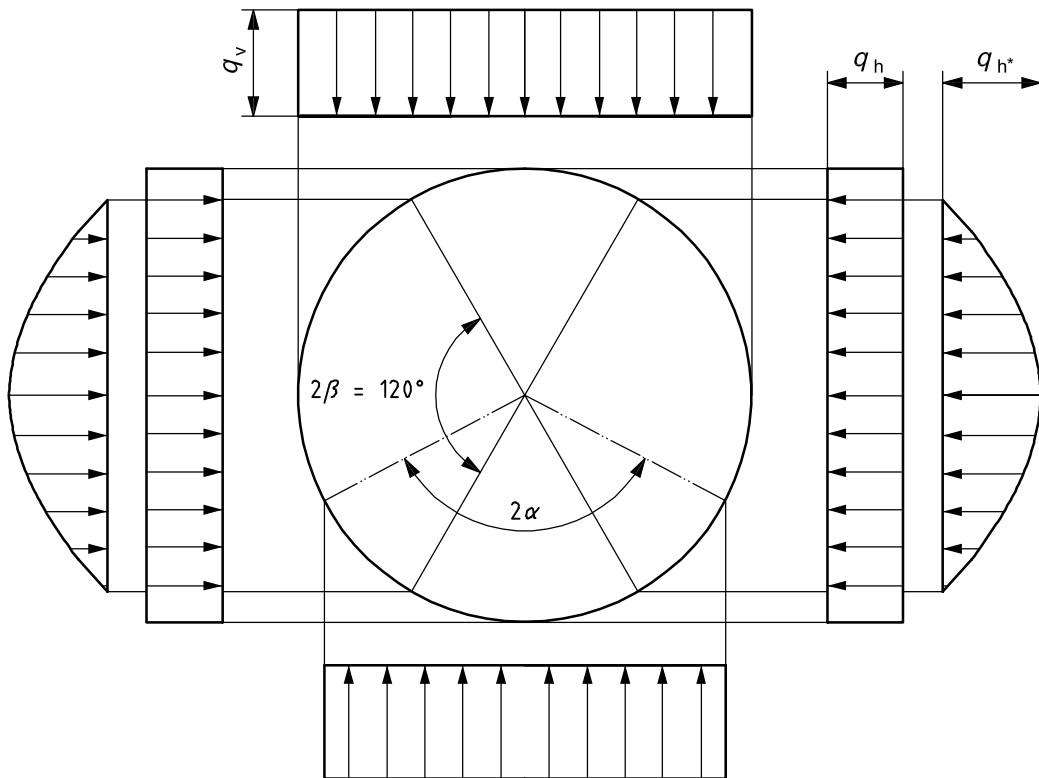

b) ATV

Figure 2 — Soil stress distribution according to Spangler and ATV-A 127

5.2.2 ATV procedure

The ATV procedure for calculating soil loads is more detailed than that used by AWWA. The procedure is based on silo theory, which assumes that frictional forces against the trench walls will lead to a reduction in the pressure acting on the pipe due to the soil. It is assumed that these friction conditions are maintained for the whole life of the pipe.

Trench and embankment conditions are considered as well as the angle of the trench walls and the relationship between the horizontal and vertical soil pressures.

When the trench width is four times the pipe diameter or greater, then ATV assumes that embankment conditions exist and consequently the soil load is a prismatic load.

The remainder of this subclause is an outline of the ATV procedure for calculating the soil load. Because of the detailed nature of this approach, the reader is strongly recommended to read ATV-A 127 in detail very carefully.

The vertical pressure, p_E , due to the prismatic soil load contains a reduction factor, κ , in Equation (2) to take into account the friction effects mentioned above:

$$p_E = \kappa \times \chi_s \times h \quad (2)$$

Similarly, friction effects change the soil pressure, p_o , applied by a uniformly distributed load (UDL) acting over a limited area, and this is expressed using the factor κ_o :

$$p'_o = \kappa_o \times p_o \quad (3)$$

NOTE κ is the reduction factor for soil load. A subscript has been used above to indicate that κ_o is the reduction factor for a UDL.

To use these reduction factors, the procedures require that:

- a) $E_1 \leq E_3$ (for κ)
- b) $E_1 < E_3$ (for κ_o)

If either of these conditions is not met or if the installation is considered to be of the embankment type, then the factors κ and κ_o are taken to be equal to 1.

The reduction factors are derived using Equations (4) and (5):

$$\kappa = \frac{1 - e^{\left(-2 \times \frac{h}{b} \times K_1 \times \tan \delta\right)}}{2 \times \frac{h}{b} \times K_1 \times \tan \delta} \quad (4)$$

$$\kappa_o = e^{\left(-2 \times \frac{h}{b} \times K_1 \times \tan \delta\right)} \quad (5)$$

where

- e is the base of natural logarithms (2,718 281 8);
- p_E is the vertical soil pressure due to the soil load, in N/m²;
- κ is the reduction factor for silo theory;
- χ_s is the bulk density of the soil (i.e. its weight per unit volume), in N/m³;
- h is the depth of cover, in m;

- κ_0 is the silo theory reduction factor for UDL;
- p_0 is the soil pressure due to the UDL, in N/m²;
- b is the trench width at spring-line, in m;
- δ is the trench wall friction angle, in degrees (see Table 2);
- K_1 is the ratio of the horizontal to the vertical soil pressure in soil zone 1.

To help in other parts of the procedures, there are four classes of installation for zone 1 material above the pipe zone (see Table 1)

Table 1 — Installation conditions

Class	Description
A1	Trench backfill compacted against undisturbed native soil in layers (without assessing degree of compaction). These conditions also apply to sheet piles left in after installation.
A2	Vertical timber sheeting or lightweight sheet piles or shields which are gradually removed in stages during installation or uncompacted fill or washing-in of the backfill (valid for soil group G1).
A3	Vertical sheeting or shields withdrawn in one operation after all the backfill material has been put in place and compacted.
A4	Same as A1 but degree of compaction is assessed. These conditions shall not be used with soil group G4.

For all the installation conditions detailed in Table 1, the lateral soil pressure acting on the trench walls, expressed in terms of the vertical to horizontal soil pressure ratio, K_1 , is assumed to be 0,5. Under these conditions, Equations (4) and (5) reduce to Equations (4a) and (5a):

$$\kappa = \frac{1 - e^{\left(-\frac{h}{b} \times \tan \delta\right)}}{\frac{h}{b} \times \tan \delta} \quad (4a)$$

$$\kappa_0 = e^{\left(-\frac{h}{b} \times \tan \delta\right)} \quad (5a)$$

The wall friction angle is derived from one of the equations given in Table 2, depending on the fill conditions.

Table 2 — Wall friction angle δ

Class	Equation
A1	$\delta = 0,66 \times \varphi'$
A2	$\delta = 0,33 \times \varphi'$
A3	$\delta = 0$
A4	$\delta = \varphi'$
NOTE	φ' is the internal friction angle, in degrees, of the soil.

In the case where $\delta = 0$, the reduction factors κ and κ_0 are taken to be equal to 1.

The other reduction factors, κ_β and $\kappa_{o\beta}$, are adjusted to take into account the trench angle, as shown by Equations (6) and (7):

$$\kappa_\beta = 1 - \frac{\beta}{90} + \left(\kappa \times \frac{\beta}{90} \right) \quad (6)$$

$$\kappa_{o\beta} = 1 - \frac{\beta}{90} + \left(\kappa_o \times \frac{\beta}{90} \right) \quad (7)$$

NOTE κ_β is the reduction factor for soil loads which takes into account the trench angle, β , and $\kappa_{o\beta}$ is the reduction factor for a UDL which takes into account the trench angle.

The horizontal soil pressure, q_h , is calculated using Equation (8):

$$q_h = K_2 \left[(\kappa \times \chi_s \times h) + (\kappa_o \times p_o) + \left(\chi_s \times \frac{d_e}{2} \right) \right] \quad (8)$$

where

d_e is the outside diameter of the pipe, in m;

K_2 is the ratio of the horizontal to the vertical pressure at the pipe spring-line (see Table 3 for $V_{RB} \leq 1$ in ATV-A 127).

K_2 values are not clearly defined soil mechanics values; they cover various types of influence with the aim of linearization and are adjusted to measured values.

The bedding reaction pressure, q_{h^*} , resulting from pipe deformation is applied as a parabola with a support angle of 120° and calculated using Equation (8a):

$$q_{h^*} = \frac{(C_{h,qv} \times q_v) + (C_{h,qh} \times q_h)}{V_{RB} - C_{h,qh}} \quad (8a)$$

Table 3 — Ground pressure ratio, K_2

Soil group	K_2
G1	0,4
G2	0,3
G3	0,2
G4	0,1

When the pipe installation work is to be checked by measurement of the pipe deflection, calculate the concentration factor in the soil adjacent to the pipe, λ_S , as described in ATV, together with the concentration factor above the pipe, λ_{PG} , using Equations (9) and (10):

$$\lambda_S = \frac{4 - \lambda_P}{3} \quad (9)$$

$$\lambda_{PG} = \left(\frac{\lambda_P - 1}{3} \times \frac{b}{d_e} \right) + \frac{4 - \lambda_P}{3} \quad (10)$$

In such cases, calculate the vertical soil pressure q_v using Equation (11):

$$q_v = \lambda_{PG} \left[(\kappa \times \chi_s \times h) + (\kappa_o \times p_o) \right] + p_v \quad (11)$$

which, in embankment situations, simplifies to Equation (12):

$$q_v = \lambda_P \left[(\chi_s \times h) + p_o \right] + p_v \quad (12)$$

and calculate the horizontal soil pressure, q_h , using Equation (13):

$$q_h = K_2 \times \left[\lambda_S (\kappa \times \chi_S \times h + \kappa_o \times p_o) + \left(\chi_S \times \frac{d_e}{2} \right) \right] \quad (13)$$

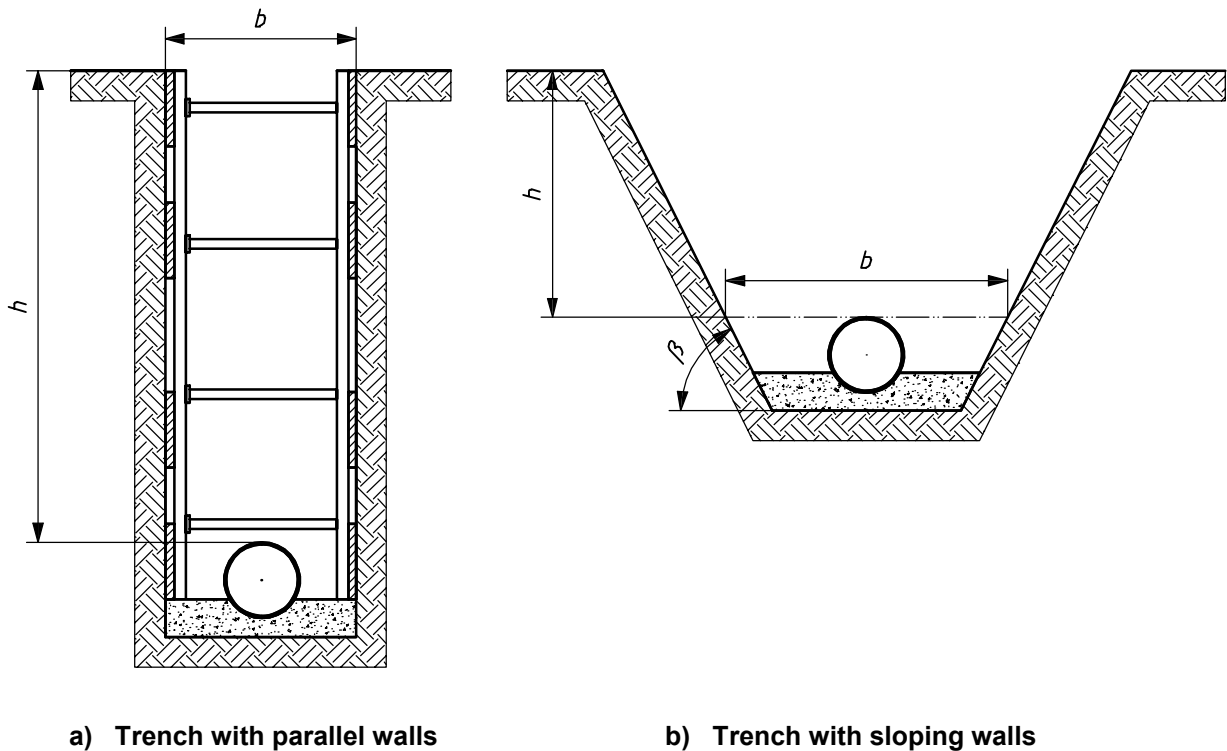

Figure 3 — Trench walls

5.3 Long-term loading

5.3.1 AWWA procedure

AWWA does not differentiate between short-term and long-term loading. However, to take into account the effects of time on deflection, a deflection lag factor is used (see 7.1.1.2).

5.3.2 ATV procedure

For all soil loads, the silo theory is used and the short-term and long-term loads are equal.

6 Traffic loads

6.1 General

Basically, the design methods used in both documents are related to the Boussinesq theory, which converts a surface wheel load into a soil pressure load applied to the pipe at the crown. The magnitude of the load applied to the pipe is a function of wheel load, burial depth and the angle of pressure dissipation.

While only traffic loads due to lorry traffic are discussed here, AWWA also discusses rail loading and ATV has extensive guidance on aircraft and rail loadings.

6.2 AWWA procedure

The following calculation is used to compute the live load on the pipe for surface traffic. The procedure is based on the requirements of AASHTO [4]. The calculations consider a single-axle truck travelling perpendicular to the pipe on an unpaved surface or a road with a flexible pavement. With the inclusion of the multiple presence factor, M_p , these conditions generally control and may be assumed to yield acceptably conservative estimates.

$$W_L = \frac{M_p \times P \times I_f}{L_1 \times L_2} \quad (14)$$

where

W_L is the live load on pipe, in N/m²;

M_p is the multiple presence factor = 1,2;

P is the magnitude of wheel load:

= 71 300 N for AASHTO HS20 truck,

= 89 000 N for AASHTO HS25 truck;

I_f is the impact factor;

L_1 is the load width parallel to direction of travel (see Figure 4), in m;

L_2 is the load width perpendicular to direction of travel (see Figure 4), in m;

$$I_f = 1 + 0,33 \left[\frac{2,44 - h}{2,44} \right] \geq 1,0 \quad (15)$$

where h is the depth of cover, in m.

$$L_1 = t_1 + (LLDF \times h) \quad (16)$$

where

t_1 is the length of tyre footprint = 0,25 m;

$LLDF$ is a factor to account for live load distribution with depth of fill:

= 1,15 for backfills SC1 and SC2,

= 1,0 for all other backfill.

If $h \leq h_{int}$ then

$$L_2 = t_w + (LLDF \times h) \quad (17)$$

where t_w is the width of tyre footprint = 0,5 m.

If $h > h_{int}$ then

$$L_2 = 0,5 [t_w + 1,83 + (LLDF \times h)] \quad (18)$$

where

h_{int} is the depth at which load from wheels interacts

$$h_{int} = \frac{1,83 - t_w}{LLDF} \quad (19)$$

Dimensions in millimetres

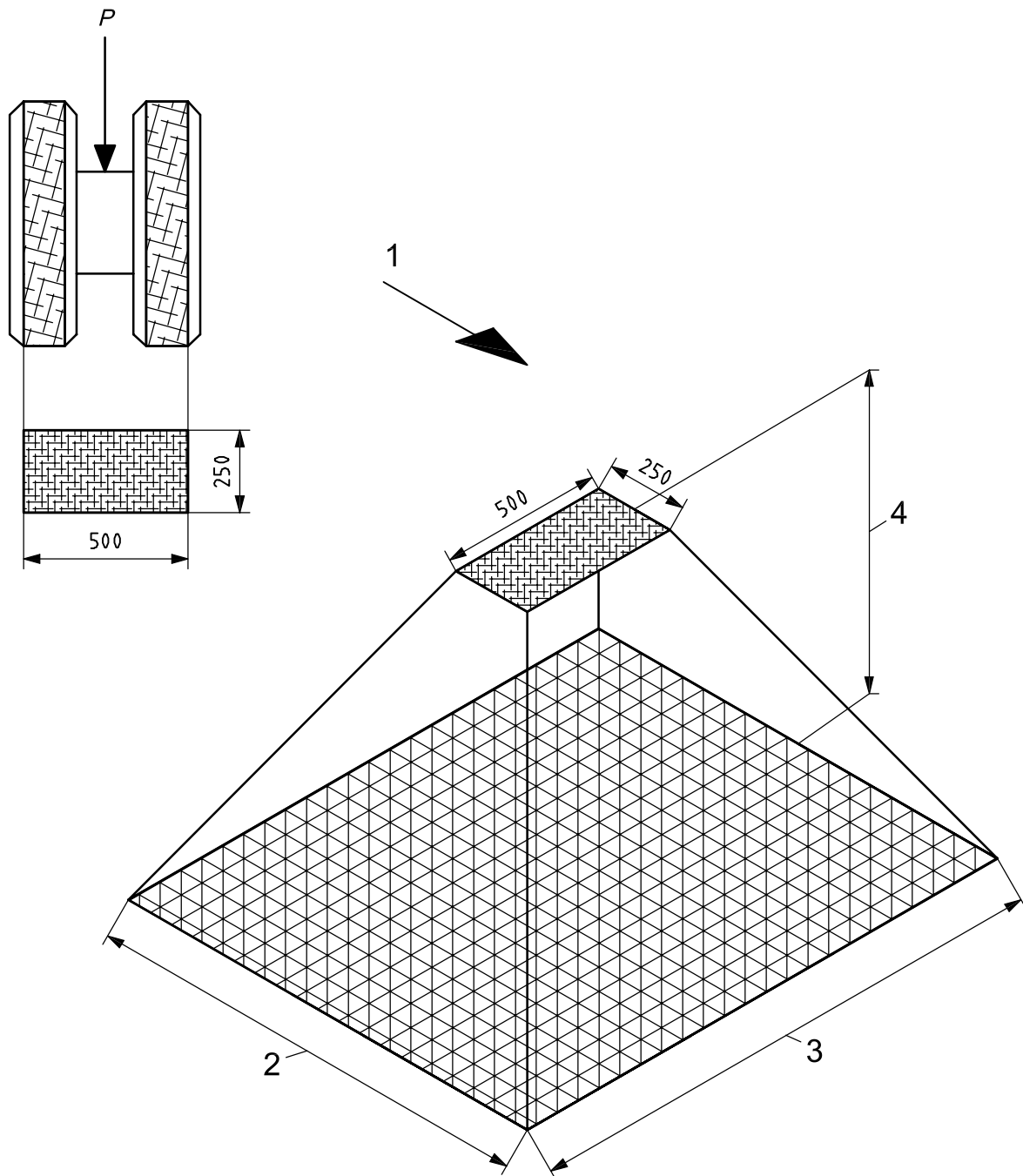

Key

- 1 direction of travel
- 2 load width parallel to direction of travel, L_1
- 3 load width at right angles to direction of travel, L_2
- 4 burial depth, h

Figure 4 — Distribution of HS20 or HS25 live load through granular fill

For tandem-axle trucks, Equation (20) can be used for L_1 if both axles load the pipe at the same time. Note that tandem-axle loads are usually lower than HS20 or HS25 trucks; for example the AASHTO design tandem load is a 55 700 N wheel load.

$$L_1 = 0,5[\text{axle spacing} + t_w + (LLDF \times h)] \tag{20}$$

The calculation is independent of pipe diameter, and with the HS20 and HS25 (71 300 N) wheel load it gives the values given in Table 4. The table gives the calculated live loads for single-axle AASHTO HS20 and HS25 trucks with an *LLDF* of 1,15 for a granular backfill.

Table 4 — HS20 and HS25 live axle loads

Depth of cover m	HS20 load kPa	HS25 load kPa
0,6	92	116
0,8	67	84
0,9	51	63
1,2	32	41
1,5	23	29
1,8	18	22
2,4	11	14
3,0	7,6	10
3,7	5,5	7,6
4,6	4,1	4,8
6,1	2,8	3,4
8,5	1,4	1,8
12,2	0,7	0,7

6.3 ATV procedure

ATV also follows the Boussinesq theory, but uses different pressure dissipation angle, wheel load and impact factor assumptions from those used by AWWA.

The soil stress, p , resulting from road traffic loads is dependent upon the cover height, h , in metres, and the mean pipe diameter, d_m , in metres, and is calculated using the approximate Equation (21):

$$p = a_f \times p_f \tag{21}$$

The distribution factor, a_f , takes into account the pressure distribution over the pipe cross-section and pipe length at various depths of fill. It is based on a pressure spread at an inclination of 2:1. Equation (22) is considered valid for the limits:

$$h \geq 0,5 \text{ m}$$

$$d_m \leq 5,0 \text{ m}$$

a_f is given by Equation (22):

$$a_f = 1 - \frac{0,9}{0,9 + \frac{4h^2 + h^6}{1,1 \times d_m^3}} \tag{22}$$

where d_m is the mean pipe diameter, in m.

According to Boussinesq, an approximation to the maximum stress, p_F , arising from wheel loads and contact areas in accordance with DIN 1072, can be calculated using Equation (23):

$$p_F = \frac{F_A}{r_A^2 \times \pi} \left\{ 1 - \left[\frac{1}{1 + \left(\frac{r_A}{h} \right)^2} \right]^{\frac{3}{2}} \right\} + \frac{3 \times F_E}{2 \times \pi \times h^2} \left[\frac{1}{1 + \left(\frac{r_E}{h} \right)^2} \right]^{\frac{5}{2}} \quad (23)$$

where

- p_F is the soil stress due to the traffic load according to Boussinesq, in N/m² ;
- F_A, F_E are the wheel loads, in kN;
- r_A, r_E are the wheel radii, in m;
- h is the depth of cover, in m;
- a_f is the distribution factor given by Equation (22).

The design loads F_A and F_E as well as the design radii r_A and r_E given in Table 5 are taken from DIN 1072.

Table 5 — Design wheel-loads and radii for standard vehicles

Standard vehicle	F_A kN	F_E kN	r_A m	r_E m
HGV ^a 60	100	500	0,25	1,82
HGV 30	50	250	0,18	1,82
CV ^b 12	40	80	0,15	2,26
^a Heavy goods vehicle.				
^b Commercial vehicle.				

Horizontal pressures due to traffic loads are not considered.

The pressures due to traffic loads are multiplied by the impact factor, φ , given in Table 6.

Table 6 — Impact factor, φ

Standard vehicle	φ
HGV 60	1,2
HGV 30	1,4
CV 12	1,5

For convenience, ATV presents the loads graphically as a function of burial depth.

7 Deflections

7.1 Resulting from vertical load

7.1.1 AWWA procedure

The AWWA system is based on Spangler's work and modifications made to it by Spangler/Watkins, commonly known as the "modified Iowa" formula [see Equation (24)]:

$$\frac{d_v}{d_m} = \frac{(D_L \times W_c + W_L) \times k_x}{8 \frac{EI}{d_m^3} + 0,061 M_s} \times 100 \quad (24)$$

where

d_v is the vertical deflection, expressed as a percentage of the mean pipe diameter;

k_x is the bedding coefficient (dimensionless);

E is the apparent flexural modulus of the pipe wall, in N/m²;

I is the second moment of area in the longitudinal direction, in m⁴/m;

d_m is the mean diameter of the pipe, in m;

M_s is the composite constrained-soil modulus of the soil reaction, in N/m²;

D_L is the deflection lag factor to allow for long-term soil consolidation (dimensionless);

W_c is the vertical soil load, in N/m²;

W_L is the traffic load, in N/m²;

AWWA has modified the formula and introduced additional considerations to allow for the effects of native soil properties and the width of the trench.

7.1.1.1 Bedding coefficient, k_x

The bedding coefficient reflects the degree of support provided by the soil at the bottom of the pipe and over which the bottom reaction is distributed. Assuming an inconsistent haunch (typical direct-burial condition), a k_x value of 0,1 should be used. For support provided by a shaped trench bottom, a value of 0,083 is appropriate.

7.1.1.2 Deflection lag factor, D_L

The deflection lag factor is used to convert short-term to long-term deflection. Long-term deflection will be higher, due to a potential increase in overburden load as soil arching is gradually lost. Other causes of increased deflection can be time-related consolidation of pipe-zone embedment and/or creep of native soil. For prediction of long-term deflection, a value greater than 1,0 has to be used for D_L . When choosing the value, due care is to be taken to consider the stiffness of the native and the pipe-embedment soils.

7.1.1.3 Composite constrained-soil modulus, M_s

The vertical loads on a flexible pipe cause a decrease in its vertical diameter and an increase in its horizontal diameter. The horizontal movement develops in the soil a passive soil resistance that provides support for the pipe. The magnitude of the soil's passive resistance varies depending upon the soil type, the degree of compaction of the pipe-zone backfill material, the native soil characteristics, the cover depth and the trench

width. To determine M_s for a buried pipe, separate M_s values for the native soil, M_{sn} , and the pipe backfill surround, M_{sb} , are determined and then combined using Equation (25):

$$M_s = S_c \times M_{sb} \quad (25)$$

where

M_{sb} is the constrained-soil modulus of the pipe-zone embedment, in N/m^2 ;

S_c is the soil support combining factor (dimensionless).

Tabulated values for M_{sn} are given in AWWA. Values for M_{sb} are a function of the vertical soil stress level, i.e. the depth of burial, as well as degree of compaction and the soil type. A table of values is given in AWWA. For pipe installed below the water table, the constrained-soil modulus of the backfill should be corrected for reduced vertical stress due to buoyancy and by an additional saturation reduction factor, variable with soil type.

Values of S_c are obtained from Table 7, where S_c is a function of trench width and the ratio of the native soil to pipe-embedment moduli. This table was developed considering the work of Leonhardt, as used in ATV, along with additional studies.

Table 7 — Values for the soil support combining factor, S_c

$\frac{M_{sn}}{M_{sb}}$	$\frac{b}{d}$							
	1,25	1,50	1,75	2,00	2,5	3,00	4,00	5,00
0,005	0,02	0,05	0,08	0,12	0,23	0,43	0,72	1,00
0,01	0,03	0,07	0,11	0,15	0,27	0,47	0,74	1,00
0,02	0,05	0,10	0,15	0,20	0,32	0,52	0,77	1,00
0,05	0,10	0,15	0,20	0,27	0,38	0,58	0,80	1,00
0,1	0,15	0,20	0,27	0,35	0,46	0,65	0,84	1,00
0,2	0,25	0,30	0,38	0,47	0,58	0,75	0,88	1,00
0,4	0,45	0,50	0,56	0,64	0,75	0,85	0,93	1,00
0,6	0,65	0,70	0,75	0,81	0,87	0,94	0,98	1,00
0,8	0,84	0,87	0,90	0,93	0,96	0,98	1,00	1,00
1,0	1,00	1,00	1,00	1,00	1,00	1,00	1,00	1,00
1,5	1,40	1,30	1,20	1,12	1,06	1,03	1,00	1,00
2	1,70	1,50	1,40	1,30	1,20	1,10	1,05	1,00
3	2,20	1,80	1,65	1,50	1,35	1,20	1,10	1,00
≥ 5	3,00	2,20	1,90	1,70	1,50	1,30	1,15	1,00

where

b is the trench width at the spring-line, in m;

d is the pipe diameter, in m;

M_{sn} is the native constrained-soil modulus, in N/m^2 ;

M_{sb} is the embedment constrained-soil modulus, in N/m^2

NOTE Intermediate values for S_c can be determined by linear interpolation between adjacent values.

7.1.2 ATV procedure

The relative vertical deflection, δ_v , given by $\delta_v = \frac{d_v}{d_m}$ (% deflection when multiplied by 100), is determined using Equation (26):

$$\delta_v = \frac{2 \times r_m}{8} \left[(C_{v,qv} \times q_v) + (C_{v,qh} \times q_h) + (C_{v,qh^*} \times q_{h^*}) \right] \quad (26)$$

The horizontal change of diameter is determined, if necessary, using Equation (27):

$$\delta_h = \frac{2 \times r_m}{8} (C_{h,qv} \times q_v + C_{h,qh} \times q_h + C_{h,qh^*} \times q_{h^*}) \quad (27)$$

where

$$q_v = \lambda_{PG} \left[(\kappa \times \chi_B \times h) + (\kappa_o \times p_o) \right] + p_v$$

$$q_h = K_2 \times \left[\lambda_S (\kappa \times \chi_B \times h + \kappa_o \times p_o) + \left(\chi_S \times \frac{d_e}{2} \right) \right]$$

$$q_{h^*} = \frac{(C_{h,qv} \times q_v) + (C_{h,qh} \times q_h)}{V_{RB} - C_{h,qh}}$$

Pipe stiffness, $S_O = \frac{E_P \times I}{d_m^3}$ (28)

$$K^* = \frac{c_{h,qv}}{V_{RB} - c_{h,qh^*}} \quad (29)$$

$C_{v,qv}$ is the deformation coefficient for δ_v as a result of q_v ;

C_{v,qh^*} is the deformation coefficient for δ_h as a result of q_{h^*} ;

$c_{v,qv}$, c_{v,qh^*} , $c_{h,qv}$, c_{h,qh^*} are deflection coefficients (see Tables 8 and 9);

$$V_{RB} = \frac{8 \times S_O}{S_{Bh}} \quad (30)$$

$$S_{Bh} = 0,6 \times \zeta \times E_2 \quad (31)$$

E_2 is the modulus of the pipe-zone soil, in N/mm² (see Figure 1);

ζ is a correction factor for the horizontal bedding stiffness, given by Equation (32):

$$\zeta = \frac{1,667}{\Delta f + (1,667 - \Delta f) \times E_2 / E_3} \quad (32)$$

$$\text{in which } \Delta f = \frac{\frac{b}{d_e} - 1}{0,980 + 0,303 \times \left(\frac{b}{d_e} - 1 \right)} \leq 1,667 \quad (33)$$

The correction factor, ζ , allows for the difference between the moduli of the pipe-embedment material and the native soil, and also for the width of the trench.

The relationship between the bedding angle 2α and the coefficients $c_{v,qv}$ and $c_{h,qv}$ is shown in Table 8.

The values of c_{v,qh^*} and c_{h,qh^*} for a bedding reaction angle of 120° are given in Table 9.

Table 8 — Values of $c_{v,qv}$ and $c_{h,qv}$ in relation to the bedding angle 2α

Bedding angle 2α	$c_{v,qv}$	$c_{h,qv}$
60°	-0,105 3	0,102 6
90°	-0,096 6	0,095 6
120°	-0,089 3	0,089 1
180°	-0,083 3	0,083 3

Table 9 — Values of c_{v,qh^*} and c_{h,qh^*} for a bedding reaction angle of 120°

Bedding reaction angle	c_{v,qh^*}	c_{h,qh^*}
120°	0,064 0	-0,065 8

7.1.2.1 Deformation modulus (secant modulus), E_S

Table 10 — Guidance value for deformation modulus of soil

Soil group number	Unit weight of soil χ_s kN/m ³	Internal friction angle φ °	Degree of compaction D_{pr} %						Exponent in Eqn. (3.02) ^b Z	Reduction factor for creep f_1
			85	90	92	95	97	100		
			Modulus of elasticity E_S N/mm ²							
G1	20	35	2 ^a	6	9	16	23	40	0,50	1,0
G2	20	30	1,2	3	4	8	11	20	0,35	1,0
G3	20	25	0,8	2	3	5	8	13	0,20	0,8
G4	20	20	0,2	1,5	2	4	6	10	0	0,5

^a E_S values $\geq 2,0$ N/mm² shall be rounded to nearest integer.

^b Equation (3.02) in ATV-A 127.

The guidance values for the characteristic properties of the four soil groups in ATV-A 127, G1 to G4, are summarized in Table 10. The values for the deformation modulus, E_s , are to be used for depths up to 5 m. For depths of cover above 5 m the deformation modulus can be calculated using:

$$E_{s,\sigma} = E_s \times \left(\frac{p_E}{100} \right)^Z \quad [\text{ATV-A 127:2000, Equation (3.02)}]$$

where

$E_{s,\sigma}$ is the deformation modulus in N/mm² at depths of cover > 5 m;

p_E is the stress applied to the soil due to earth load and surface load, in kN/m²;

NOTE The applied stress is 20 kN/m depth of cover.

Z is the exponent, as given in Table 10, for the applicable soil group;

E_s is the deformation modulus, in N/mm², from Table 10 or calculated using:

$$E_s = \frac{40}{G} \times e^{-0,188(100-D_{pr})} \quad [\text{ATV-A 127:2000, Equation (3.01)}]$$

where

G is the soil group number, i.e. for group G1 it is 1;

e is the base of natural logarithms, approximately 2,718 281 828;

D_{pr} is the degree of compaction based on simple proctor density, as a percent.

When a site investigation has been carried out and the appropriate soil properties determined, then these values may be used instead of the tabulated or calculated values. When a cohesive or organic soil, which is not covered by Table 10, is encountered, then its characteristic properties have to be determined including the creep behaviour.

The effective deformation modulus, E_2 , is calculated using Equation (34):

$$E_2 = f_1 \times f_2 \times \alpha_B \times E_{20} \quad (34)$$

where

f_1 is a reduction factor for creep from Table 10;

f_2 is a factor that takes into account the effect of groundwater in the pipe zone;

α_B is a reduction factor taking into account trench proportions and embedding condition [see Equation (35)]:

$$\alpha_B = 1 - \left(4 - \frac{b}{d_e} \right) \times \frac{1 - \alpha_{Bi}}{3} \leq 1 \quad (35)$$

where

α_{Bi} is obtained from Figure 5;

E_{20} is obtained from Table 10.

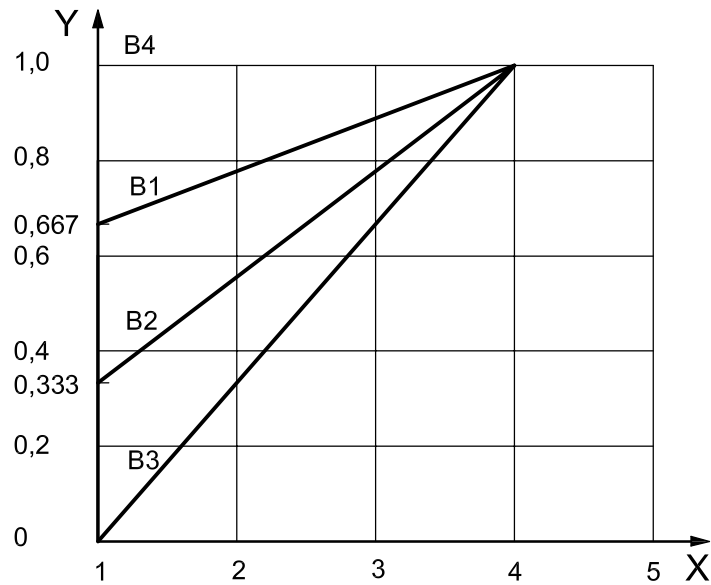
**Key**X *b/d*Y α_{B_i} **Figure 5 — Reduction factors α_{B_i} for E_2** **7.1.2.2 Embedment conditions around the pipe**

There are four embedment conditions, labelled B1 to B4.

- B1** The embedment material is compacted in layers against the native soil or in the embanked covering (without verification of the degree of compaction). This condition also applies to beam pile walls.
- B2** Vertical shuttering, using trench sheeting in the pipe zone, which reaches the bottom of the trench and is withdrawn after backfilling.

Shuttering plates or equipment on the assumption that the compaction of the soil takes place after the trench sheeting is withdrawn.
- B3** Vertical shuttering using sheet piling or light-weight piling profiles in the pipe zone. The shuttering reaches down below the bottom of the trench, and the embedment is compacted against the sheeting.
- B4** Embedment material compacted in layers against the native soil or in the embanked covering (with verification of the degree of compaction). Covering condition A4 is not applicable when using soil of Group 4.

7.1.2.3 Short-term versus long-term deflection

In ATV, the difference between short-term and long-term deflections is addressed largely by determining which short-term and long-term pipe stiffnesses are to be assessed for the product being considered.

In addition, for very weak soils the soil modulus is reduced by 50 %.

Table 11 — Representative values for the deformation moduli, E_1 and E_{20} , independent of the initial compaction

Trench backfill condition	A1		A2 and A3 ^b		A4	
Embedding condition	B1		B2 and B3		B4	
Soil group	D_{pr} ^a %	E_1, E_{20} N/mm ²	D_{pr} ^a %	E_1, E_{20} N/mm ²	D_{pr} ^a %	E_1, E_{20} N/mm ²
G1	95	16	90	6	97	23
G2	95	8	90	3	97	11
G3	92	3	90	2	95	5
G4	92	2	90	1,5	—	—

NOTE 1 With equal compaction of the soil alongside and above the pipe, $E_{20} = E_1$ can be achieved. E_{20} may not be assumed to be greater than E_1 except when the soil in the pipe embedment zone is imported or embedment condition B4 applies. The possibility of lower compaction alongside the pipe in narrow trenches is taken into account in reduction factor α_B . Subsidence, as a result of the influence of groundwater in the pipe embedment zone, is taken into account by a reduction of the E_{20} value by the use of factor f_2 derived from the following equation:

$$f_2 = \frac{D_{pr} - 75}{20} \leq 1$$

NOTE 2 E_{20} is a tabulated value used to calculate E_2 [see Equation (34)].

^a D_{pr} shall be applied for the calculation in accordance with the tabulated value for the respective embedding.
^b Compaction and deformation moduli according to A2 and A3 shall only be used if the initial compaction A1 is maintained.

7.2 Aspects not covered by AWWA or ATV

7.2.1 Deflection due to weight of pipe

Neither AWWA nor ATV includes deflection due to the weight of the pipe.

7.2.2 Initial ovalization

When a trench is backfilled, the compaction of the side fill can lead to the pipe having an increased vertical diameter (initial ovalization), the extent of which will depend on the type of soil used for the pipe embedment, its degree of compaction and the stiffness of the pipe. Neither AWWA nor ATV includes initial ovalization in the deflection calculations.

7.3 Irregularities in the installation

7.3.1 General

The accuracy of any deflection calculation will depend on the input parameters and the ability of the operators installing the pipe to achieve the specified conditions. Typical potential causes of variations in deflection include:

- an uneven pipe bed;
- variations in the trench width;
- variations in the depth of burial;
- variations in native soil properties;
- the fact that the degree of soil compaction is different from that specified;
- unplanned surface loading.

Such irregularities can increase (or decrease) pipe deflection and pipe strain compared to the calculated values.

7.3.2 AWWA procedure

There are no formal methods given in AWWA to address irregularities in the installation. However, it is implied that one could consider the effects of different native-soil and pipe-embedment moduli and/or levels of compaction from those used in design.

7.3.3 ATV procedure

ATV requires that the pipe-embedment modulus be reduced to 2/3 of the design value to allow for variations in installation.

8 Circumferential bending strain

NOTE Circumferential bending strain is determined at the top and bottom inside surfaces of the pipe. Compressive strains are negative and tensile strains are positive.

8.1 AWWA procedure

The long-term circumferential strain is calculated using Equation (36):

$$\varepsilon = D_f \times \frac{d_{vA}}{d_m} \times \frac{e}{d_m} \quad (36)$$

where

D_f is the shape (deformation) factor, dimensionless;

d_{vA} is the maximum permissible long-term vertical pipe deflection, in mm.

Values of D_f are given in Table 12 as a function of pipe stiffness and embedment compaction.

Table 12 — D_f values

Pipe stiffness N/m ²	Pipe-zone backfill material and degree of compaction			
	Gravel		Sand	
	Dumped to slight	Moderate to high	Dumped to slight	Moderate to high
1 250	5,5	7,0	6,0	8,0
2 500	4,5	5,5	5,0	6,5
5 000	3,8	4,5	4,0	5,5
10 000	3,3	3,8	3,5	4,5

The maximum permissible pipe deflection as stated by the manufacturer is to be used in all calculations even if the predicted deflection is lower.

8.2 ATV procedure

The flexural strain, ε , is calculated from Equation (37):

$$\varepsilon = \frac{e}{2 \times r_m^3 \times 8 \times S_0} \times \left(\frac{e \times N}{6} + M \times \alpha_k \right) \quad (37)$$

where

e is the wall thickness of the pipe, in mm;

N is the sum of the normal forces produced by the action of six influences (see below);

M is the sum of the bending moments produced by the action of the six influences;

r_m is the mean radius of the pipe, in m;

S_O is the pipe stiffness, N/m²

α_{κ} is a correction factor for extreme fibre curvature of the inner and outer edges, calculated using Equation (38a) or 38b) as applicable:

$$\alpha_{\kappa i} = 1 + \frac{1}{3} \times \frac{e}{r_m} = \frac{3 \times d_i + 5 \times e}{3 \times d_i + 3 \times e} \quad (38a)$$

$$\alpha_{\kappa e} = 1 + \frac{1}{3} \times \frac{e}{r_m} = \frac{3 \times d_i + e}{3 \times d_i + 3 \times e} \quad (38b)$$

where

$\alpha_{\kappa i}$ is the correction factor for curvature of the inner edge;

$\alpha_{\kappa e}$ is the correction factor for curvature of the outer edge;

r_m is the mean radius of the pipe, in m;

d_i is the internal diameter of the pipe, in m.

The six influences mentioned are:

- a) vertical loads;
- b) lateral pressure derived from vertical loads;
- c) lateral pressure derived from pipe deflection;
- d) the weight of the pipe;
- e) the weight of the pipe contents;
- f) internal or external water pressure.

The maximum allowable strain, ε_R , is calculated using Equation (39):

$$\varepsilon_R = \pm 4,28 \times \frac{e}{d_m} \times \frac{d_{vA}}{d_m} \quad (39)$$

where

e is the wall thickness of the pipe, in mm;

d_m is the mean diameter of the pipe, in mm;

d_{vA} is the maximum permissible vertical deflection, in mm.

The value obtained using Equation (37) has to be compared to the value determined using Equation (39). For flexible pipes such as those of GRP, where long-term properties are verified, the following weighted values for stress and strain have to be determined using Equation (40) or (41) as appropriate:

$$\bar{\sigma}_R = \frac{(p_E \times \sigma_{PL}) + (p_V \times \sigma_{PK})}{p_E + p_V} \quad (40)$$

or

$$\bar{\varepsilon}_R = \frac{(p_E \times \varepsilon_{PL}) + (p_V \times \varepsilon_{PK})}{p_E + p_V} \quad (41)$$

where

- $\bar{\sigma}_R$ is the weighted bending tensile strength;
- p_E is the stress in soil due to prismatic soil load;
- p_V is the stress in soil due to traffic load;
- σ_{PL} is the long-term bending tensile stress;
- σ_{PK} is the initial bending tensile stress;
- $\bar{\varepsilon}_R$ is the weighted calculated value of outer fibre strain;
- ε_{PL} is the long-term bending tensile strain;
- ε_{PK} is the initial bending tensile strain.

9 Buckling

9.1 General

There is a significant difference in approach between ATV and AWWA regarding calculation of the critical buckling pressure, q_c . In ATV, the effect of groundwater on the buckling resistance is considerable at shallow burial depths.

9.2 AWWA procedure

The AWWA approach to buckling recognizes the supporting effect of the soil. The summation of appropriate external loads should be equal to or less than the allowable buckling pressure. The allowable buckling pressure, q_a , is determined using Equation (42):

$$q_a = \frac{(1,2 \times C_n)(E \times I)^{0,33} (\varphi_S \times 10^6 \times M_s \times k_v)^{0,67} R_h}{(FS \times r)} \quad (42)$$

where

- q_a is the allowable buckling pressure, in kPa;
- FS is the design factor = 2,5;
- C_n is the buckling scalar calibration factor to account for some non-linear effects = 0,55;

M_s is the composite constrained-soil modulus, in MPa;

r is the mean pipe radius, in m;

φ_S is a factor to account for variability in stiffness of compacted soil; suggested value is 0,9;

k_v is a modulus correction factor for the Poisson ratio, ν , of the soil

$$= (1 + \nu) (1 - 2\nu) / (1 - \nu);$$

NOTE In the absence of specific information, it is common to assume $\nu = 0,3$ giving $k_v = 0,74$.

R_h is a correction factor for depth of fill;

$$R_h = \frac{11,4}{\left(11 + \frac{0,001 \times D}{h}\right)}$$

D is the mean pipe diameter, in mm;

h is the height of ground surface above top of pipe, in m.

The buckling requirement is met for normal pipe installations by satisfying the inequality (43):

$$(\gamma_w \times h_w) + (R_w \times W_c) + P_v \leq q_a \quad (43)$$

where

γ_w is the density of water, in MN/m³;

R_w is the water buoyancy reduction factor:

$$R_w = 1 - \frac{0,33 \times h_w}{h}$$

where

h_w is the height of the groundwater level above the top of the pipe [$0 \leq h_w \leq h$], in m,

h is the height of soil above the top of the pipe, in m,

q_a is the permissible buckling pressure, in N/m²,

P_v is the internal under-pressure, in N/m²;

or, with traffic loads:

$$(\gamma_w \times h_w) + (R_w \times W_c) + W_L \leq q_a \quad (44)$$

where W_L is the traffic load, in N/m².

It is assumed that traffic loads will not occur simultaneously with internal under-pressure.

9.3 ATV procedure

In the ATV system, the *in situ* (native) soil is considered along with the pipe-zone backfill material. The combined effect is shown in Equation (45):

$$\text{Critical } q_v = 2 \times \kappa_{v2} \times \sqrt{S_{Bh} \times 8 \times S_O} \quad (45)$$

where

$$S_{Bh} = 0,6 \times \zeta \times E_2 \quad (46)$$

$$S_O = \frac{EI}{d_m^3} \times 10^{-6} \quad (47)$$

κ_{v2} is determined from a graph (D 11) in ATV-A 127

$$\text{In Equation (45), } S_O \text{ is replaced by } \bar{S}_o = \frac{p_E \times S_{OL} + p_v \times S_{OK}}{p_E + p_v} \quad (48)$$

where

\bar{S}_o is the weighted pipe stiffness;

p_E is the soil stress due to earth load, in kN/m²;

p_v is the soil stress due to traffic load, in kN/m²;

S_{OL} is long-term (2 year) pipe stiffness, in N/mm²;

S_{OK} is long-term (50 year) pipe stiffness, in N/mm².

The safety factor against buckling is calculated using Equation (49):

$$FS = \frac{\text{Critical pressure}}{\text{Actual pressure}} = \frac{\text{Critical } q_v}{q_v} \quad (49)$$

The actual pressure, q_v , includes soil and traffic loads.

If groundwater is present, then this effect shall also be considered. The critical external water pressure at the pipe spring-line is determined from Equation (50):

$$\text{Critical } p_e = \kappa_{a2} \times \alpha_D \times 8 \times S_O \quad (50)$$

where

α_D is a snap-through coefficient which is a function of the ratio of pipe radius to wall thickness, r_m/e , the ratio of pipe stiffness to soil stiffness, $V_{RB} = 8S_O/S_{Bh}$, and a reduction factor κ_{a2} that takes into account initial deformation (see Figure 6).

The actual external water pressure, i.e. the hydrostatic pressure at the pipe spring-line, is calculated using Equation (51):

$$p_e = \chi_w \left(h_w + \frac{d_e}{2} \right) \quad (51)$$

where χ_w is the unit weight of water, in N/m³.

The safety factor, FS , is given by Equation (52):

$$FS = \frac{\text{Critical } p_e}{\text{Actual } p_e} \quad (52)$$

If not only soil and traffic loads but also groundwater are taken into account, then the overall factor of safety against buckling, χ , is given by Equation (53):

$$\chi = \frac{1}{\frac{q_v}{\text{Critical } q_v} + \frac{p_e}{\text{Critical } p_e}} \quad (53)$$

ATV-A 127 recommends the following minimum safety factors.

a) Against failure due to fracture:

- 2,0 for a probability of failure of 10⁻⁵, i.e. 1 in 100 000 (normal case);
- 1,75 for a probability of failure of 10⁻³, i.e. 1 in 1 000 (special case).

b) Against failure due to instability:

- 2,0 for a probability of failure of 10⁻⁵, i.e. 1 in 100 000 (normal case);
- 1,6 for a probability of failure of 10⁻³, i.e. 1 in 1 000 (special case).

These factors are based on the assumption that the initial deformation has been taken into account. If it has not, then the factors should be increased to 2,5 and 2,0 respectively.

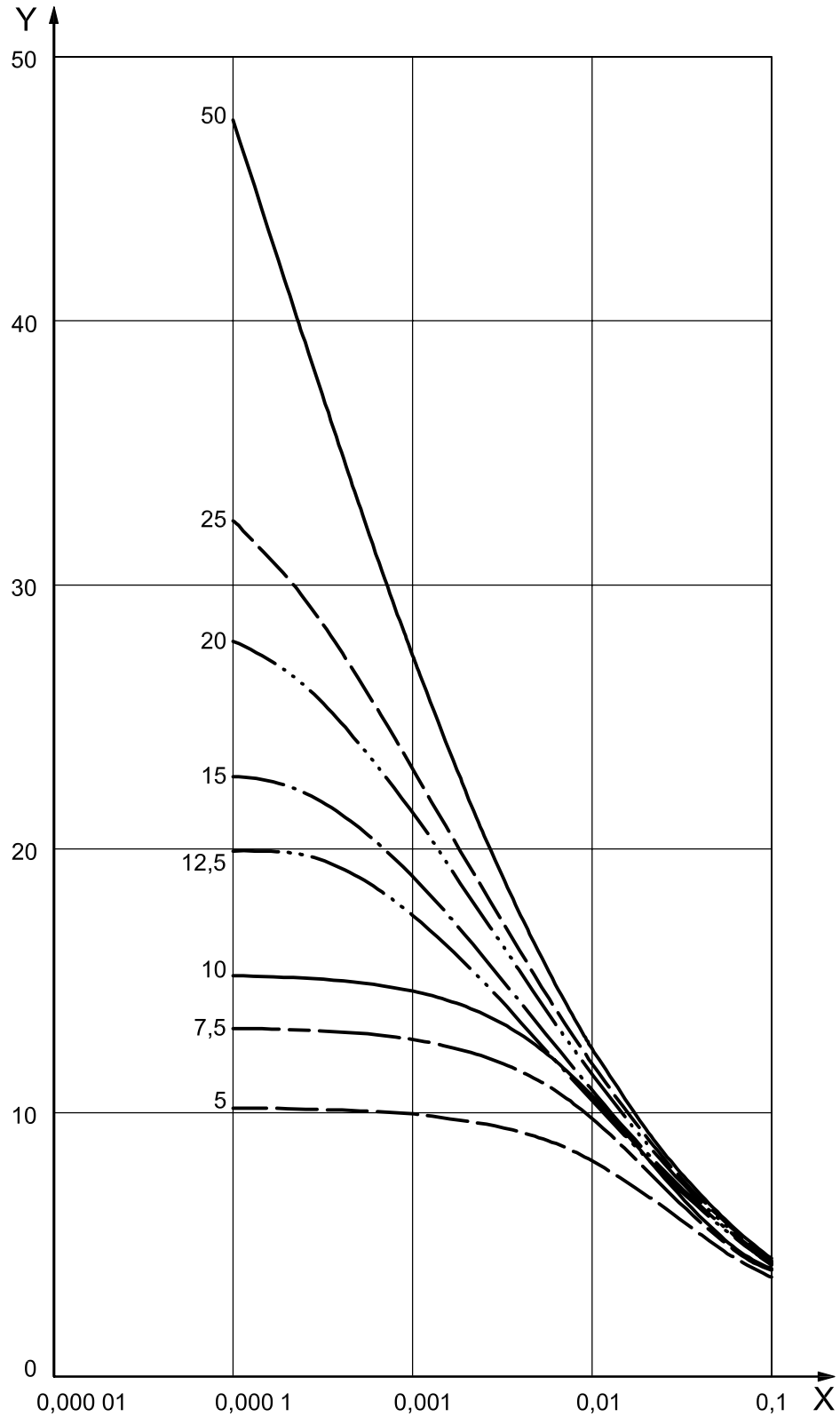

Key

X V_{RB}

Y α_D

NOTE The numbers against the curves, i.e. 50 to 5, represent the ratio of pipe radius to wall thickness, r_m/e .

Figure 6 — Plot of snap-through coefficient, α_D , for critical external water pressure

10 Internal-pressure effects

10.1 General

AWWA addresses both pressure and non-pressure pipes, while ATV is principally a non-pressure-pipe design document. ATV assumes that flexural and hoop strains are equivalent and does not consider rerounding. Therefore a comparison of the two approaches cannot be made. However, the AWWA method will be discussed briefly.

10.2 Pressure strain

The circumferential strain in the pipe wall due to internal pressure is calculated using Equation (54):

$$\varepsilon_{pr} = \frac{P_w \times d_m}{2 \times e \times E_{TH}} \quad (54)$$

where

P_w is the working pressure, in N/m² (1 bar = 10⁵ N/m²);

d_m is the mean diameter of the pipe, in mm;

e is the pipe wall thickness, in mm;

E_{TH} is the tensile hoop modulus of the pipe, in N/m².

The maximum permissible pressure strain, ε_{max} , is related to the long-term 50 year strength, or *HDB*, of the pipe as shown by Equation (55):

$$\varepsilon_{max} = \frac{HDB}{FS} \quad (55)$$

The minimum value of the safety factor, *FS*, is 1,8.

10.3 Combined loading

AWWA requires the determination of the combined effects of pressure and bending using Equations (56) and (57):

$$\frac{\varepsilon_{pr}}{HDB} \leq \frac{1 - \left(\frac{\varepsilon_b \times r_c}{S_b} \right)}{FS_{pr}} \quad (56)$$

$$\frac{\varepsilon_b \times r_c}{S_b} \leq \frac{1 - \left(\frac{\varepsilon_{pr}}{HDB} \right)}{FS_b} \quad (57)$$

where

FS_{pr} is the pressure safety factor (= 1,8);

FS_b is the bending safety factor (= 1,5);

r_c is the rerounding coefficient (dimensionless), given by:

$$r_c = 1 - \frac{P_w}{30} \quad (\text{with } P_w \text{ in bars}) \quad (58)$$

ε_{pr} is the working strain due to internal pressure, given by:

$$\varepsilon_{pr} = \frac{P_w \times d_m}{2 \times t \times E_{TH}} \quad (59)$$

ε_b is the bending strain caused by the maximum permitted deflection, given by:

$$\varepsilon_b = D_f \times \left(\frac{\delta_d}{d_m} \right) \times \left(\frac{e}{d_m} \right) \quad (60)$$

where δ_d is the maximum permitted long-term installed deflection, in mm;

HDB is the 50 year extrapolated pressure strain;

S_b is the 50 year extrapolated ring-bending strain.

The maximum permitted deflection has to be used in all calculations.

10.4 Calculations based on stress

AWWA allows pressure effects to be determined on either a strain or a stress basis. Only the more commonly used strain basis has been described here.

Bibliography

- [1] ISO/TS 10465-1:2007, *Underground installation of flexible glass-reinforced pipes based on unsaturated polyester resin (GRP-UP) — Part 1: Installation procedures*
- [2] ISO/TR 10465-3:2007, *Underground installation of flexible glass-reinforced pipes based on unsaturated polyester resin (GRP-UP) — Part 3: Installation parameters and application limits*
- [3] DIN 1072, *Road and foot-bridges — Design loads*
- [4] AASHTO. *AASHTO LRFD bridge design specifications*, 2nd edition. American Association of State Highway and Transportation Officials, Washington, DC, 1998

